

A Discussion on Pellistor Gas Sensor Responses

Pellistor gas sensors have been used for several decades to monitor the presence of combustible gases. They provide a measure of the combustibility of the environment in which they are placed and are capable of detecting almost all combustible gases within their explosive ranges. Pellistors are used worldwide in all major applications requiring detection of explosive gas levels. This article discusses the science behind the pellistor response, why different gases respond by differing amounts and some of the factors affecting the gas response.

The name "pellistor" stems from the original description of this sensor type as a "pelletised resistor". It consists of two parts, a detector element and a compensator element, both of which are formed as beads on wire coils. The coils serve to heat the beads when electrical current is passed through them and also to detect changes in temperature of the beads caused by ambient conditions. A pellistor is, in effect, a type of calorimeter and to provide stability with known temperature characteristics the coils are typically made from platinum wire. The detector

bead contains a catalyst to promote combustion of gases and the compensator is poisoned to prevent such combustion. They are typically used in a Wheatstone bridge arrangement where the out of balance voltage from the bridge is the measurement used.

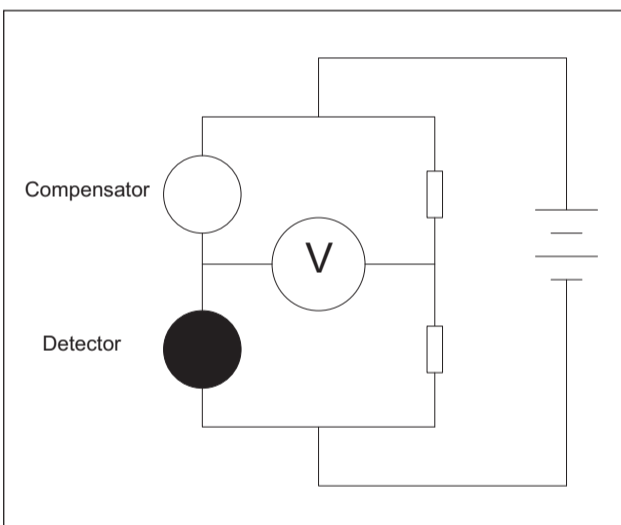

Typically, a voltage supply powers the detector in series with the compensator and also powers balancing resistors that form the other half of the Wheatstone bridge. The out of balance voltage of the bridge circuit is measured and converted to a reading of %lel. The voltage supply heats the coils so that the beads are both raised to a temperature in the region of 500°C. In the presence of combustible gas, the catalyst within the detector element causes the gas to combust. This releases heat of combustion to the detector element and raises the temperature of the detector coil. This leads to an increase in the detector coil resistance and the voltage across the detector element rises. The rise in detector voltage results in an out-of-balance voltage signal from the Wheatstone bridge.

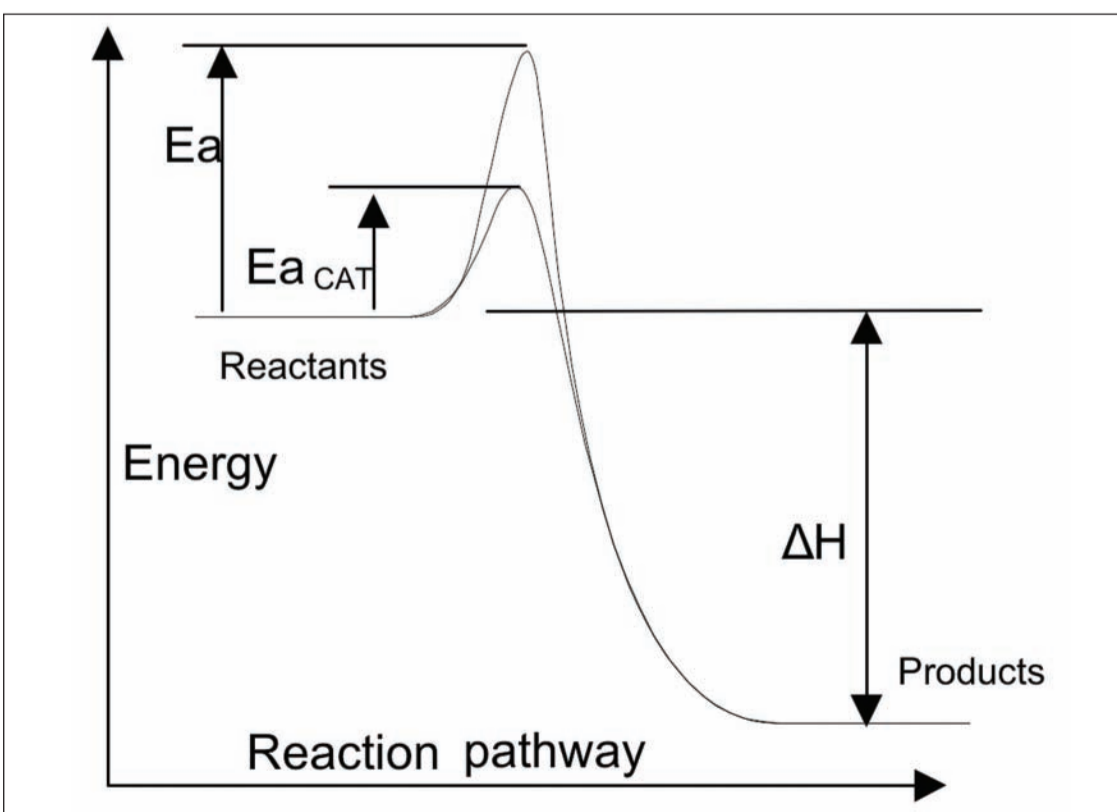

The basic relationship leading to the response from a pellistor can be described as

$$\text{Power In} + \text{Heat From Combustion} - \text{Power Loss} = \text{Response Energy}$$

The Power In is effectively the electrical power heating the coil. The Power Loss comprises heat losses through convection, radiation and conduction of heat down the lead wires of the coils to their mountings. The Response Energy is converted into a temperature rise of the beads and therefore a resistance rise of the coils. The Heat From Combustion is a function of the heat of combustion of the gas and the flux of gas.

The Power In can be described as $V \times I$ where V is the voltage across the coil and I is the current flowing through the coil. The Power Loss can be described as $f(T_{\text{Bead}} - T_{\text{Amb}})$ where T_{Bead} is the temperature of the bead and T_{Amb} is the ambient temperature. The conversion of Response Energy to temperature can be described as $M \times C_p \times \Delta T_{\text{Bead}} = \text{Response Energy}$ where M is the mass of the element, C_p is the specific heat of the element and ΔT_{Bead} is the temperature rise of the element.

For an ideal compensator there is no Heat From Combustion as it is a poisoned bead and isolated from the Heat From Combustion generated by the detector. So the compensator temperature can be determined from

$$\Delta T_{\text{Comp}} = ((V \times I) - f(T_{\text{Comp}} - T_{\text{Amb}})) / (M \times C_p)_{\text{Comp}}$$

As electrical power is applied to the compensator, the temperature of the compensator rises until it reaches a point where the Power Loss balances the Power In. For a fixed amount of Power In the temperature of the compensator reaches a level from which it is then affected largely by the thermal conductivity of the environment and the ambient temperature. In the absence of combustible gas the same applies to the detector element and, provided the detector and compensator elements are matched, the voltage signal from the Wheatstone bridge remains constant with changes in ambient conditions.

For the detector element there is the added factor of the Heat From Combustion and this leads to a relationship where the detector temperature can be determined from

$$\Delta T_{\text{Det}} = ((V \times I) - f(T_{\text{Det}} - T_{\text{Amb}}) + \text{Heat From Combustion}) / (M \times C_p)_{\text{Det}}$$

For a fixed amount of Power In the temperature of the detector reaches a level from which it is also affected by the thermal conductivity of the environment and the ambient temperature. However, the temperature of the detector also increases in the presence of combustible gas and this results in the overall pellistor response.

The catalyst is required to reduce the activation energy, a term introduced by Svante Arrhenius in 1889, which is the minimum energy required in order for a reaction to proceed. The activation energy, E_a , is a potential energy barrier between reactants and products that must be overcome for the reaction to proceed. It is linked to the energy of a transition state that exists in the reaction mechanism. A catalyst lowers the energy of the transition state and therefore lowers the activation energy, allowing the reaction to proceed at lower energy. As the source of energy to drive the reaction is the heat generated by the coil, the use of a catalyst allows the reaction to proceed at lower electrical power.

As the voltage across a pellistor is increased the energy of the beads increases and as sufficient energy starts to become available to combust the gas the pellistor signal rises. With increasing voltage this signal reaches a plateau stage where the heat from the combustion is balanced by the heat losses and then with further increase in voltage the heat losses start to increase and the response drops off. A plot of this response for a fixed gas concentration versus voltage is commonly called a peaking curve. Normally the pellistor is designed so that the methane response is on the plateau region at the normal operating voltage. Methane has a higher activation energy for combustion than most other commonly encountered combustible gases and the plateau region for other gases is typically at a lower operating voltage than that for the plateau region for methane.

Firth, Jones and Jones¹ described the response of a pellistor to different combustible gases in %lel terms by considering the heat of

combustion, the lower explosive level and the flux of gas in terms of diffusion to the active sites on the detector element. The output of a pellistor at the lower explosive limit (lel) of a fuel was described by the expression:

$$V_{(LEL)} = K D_{12} \Delta H [LEL]$$

Where $V_{(LEL)}$ is the voltage output at the lel, K is a constant, D_{12} is the diffusion coefficient, ΔH is the heat of oxidation and $[LEL]$ is the lower explosive limit of the fuel in air.

The constant K is a function of the pellistor construction and can be considered as being related to $(M \times C_p)$ in the above equations. It is therefore useful to consider the response relative to a standard gas, i.e. methane, in order that K does not enter into the considerations of relative response.

The lel of many gases are known and listed in standards such as IEC61779².

The heat of oxidation for several gases were obtained either from reported measurements or by using the group additivity scheme of Benson's group^{3,4}. This scheme allows the enthalpy of formation, entropy and heat capacity of a molecule to be quite accurately estimated by using additivity rules whereby contributions from component groups of atoms within a molecule are summed. A group additivity tool is available on line through the NIST Chemistry Webbook at <http://webbook.nist.gov/chemistry/grp-add/>. The heat of oxidation is essentially the difference between the energy of the products of combustion and the energy of the reactants (fuel and oxygen). It has to be assumed that complete combustion of fuel occurs on the pellistor for this heat of oxidation to be valid.

So with the lel and the heat of oxidation known we need to find the values of D_{12} , the diffusion coefficient, in order to estimate values for the response of a pellistor to a gas. The diffusion coefficient required is that of the gas in air, generally considered as the binary mixture of relevance, and the kinetic theory of gases relates the diffusion to the intermolecular forces acting between the gas and air. The Hirschfelder, Bird and Spotz method⁵ was used by Firth, Jones and Jones to calculate the diffusion coefficient. This method stems from the kinetic theory of gases which leads to an expression for the diffusion coefficient of:

$$D_{12} = b T^{3/2} / (\mu^{1/2} (\sigma_{12})^2 \Omega(T^*))$$

Where b is a constant and T is the absolute temperature. The reduced molecular weight of the system μ is:

$$\mu = M_a M_g / (M_a + M_g)$$

Where M_a is the mean molecular weight of air and M_g is the molecular weight of the gas to be combusted.

The collision cross section σ_{12} can be estimated from critical parameters using the expression:

$$\sigma_{12} = 0.1866 (V_c)^{1/3} (Z_c)^{-1.2}$$

Where V_c is the critical volume and Z_c is the critical compressibility of the gas.

The constant $\Omega(T^*)$ is a collision integral at a reduced temperature of T^* . This reduced temperature T^* is:

$$T^* = k T / \epsilon_{12}$$

Where k is the Boltzmann constant and ϵ_{12} is the Lennard-Jones energy interaction parameter. This molecular interaction parameter ϵ_{12} can be found from viscosity data or estimated from:

$$\begin{aligned} \epsilon_{12} / k &= ((65.3T_c(Z_c)^{3.6})_{air} (65.3T_c(Z_c)^{3.6})_{gas})^{0.5} \\ &= (78.6 (65.3T_c(Z_c)^{3.6})_{gas})^{0.5} \end{aligned}$$

Where T_c is the critical temperature of the gas.

An approximate equation for the collision integral $\Omega(T^*)$ for non-polar molecules was published by Neufeld et al⁶ as:

$$\Omega(T^*) = 1.06036 / (T^*)^{0.15610} + 0.193 / \exp(0.47635T^*) + 1.03587 / \exp(1.52996T^*) + 1.76474 / \exp(3.89411T^*)$$

An alternative approximation used by Firth, Jones and Jones is:

$$\Omega(T^*) = 1.41257(T^*)^{1.66334} - 0.971012(T^*)^{1.84982} + 0.994141(T^*)^{0.141179}$$

So in the absence of published diffusion coefficient for a given gas in air it can be estimated using the above expressions. This leads to a value for the output voltage of a pellistor in an lel concentration of gas and is normally considered relative to the methane response. This is very useful for cases where there is an absence of experimental response data. Some pellistor types are optimised for detecting combustible gases other than methane (ie their catalysts are not optimised for methane combustion) and for those devices the response can be estimated relative to butane.

Relative responses to simple alkanes, calculated using the above expressions, are shown in Table 1.

The response is therefore heavily dependent on the diffusion coefficient of the gas in air and the activity of the catalyst. The diffusion coefficients described above relate to gas diffusing through air but there are additional diffusion barriers present in a typical pellistor arrangement that also affect the overall diffusion rate:

a) There is a "depletion zone" around the pellistor where

combustion products are diffusing away from the bead while fuel and oxygen are diffusing back towards the bead. This zone has a small effect on the diffusion of gas to the active catalytic sites.

b) Some pellistors have fully open cans whilst others have "closed" cans containing a small hole for gas access. Gas diffusion is affected by the restriction of a "closed" can and the output for devices in "closed" cans tends to be less than those of open cans.

c) Flame arrestors are required to be used with pellistor sensors in order to prevent propagation of the combustion to the surrounding environment. These also affect the diffusion of gas since the gas has to diffuse through the flame arrestor before reaching the vicinity of the pellistor. Heavier molecules can give lower responses than expected by the theoretical treatment simply because they have a much lower rate of diffusion through the flame arrestor than the reference gas (normally methane).

d) Some pellistor constructions have porous structures that are used to provide an extremely high surface area of catalyst. This is used to provide some poison resistance where the presence of poisons removes catalytic activity from the outer layers of catalyst but the inner layers are still active and produce a response. However, the gas has to diffuse into the structure of the pellistor itself in order to reach the active catalyst and equally combustion products have to diffuse out of the structure. This results in porous structured pellistors generally having a lower sensitivity than a non porous structure (where the catalyst is available on the outer surface of the bead).

Under normal operation, the rate determining step for the combustion is the diffusion rate of the fuel to the pellistor. The effect of poisons, in particular silicon containing compounds or alkylated heavy metals, is to remove active catalyst sites from the pellistor structure. The mechanism of poisoning is either passivation caused by deposition of solids over the catalyst or passivation caused by chemical bonding to the catalyst. Both remove active catalyst availability.

Poison resistant structures provide a reasonably good level of protection against commonly encountered poisons. However, once sufficient poison has reached the catalyst the rate of reaction becomes dependent on the amount of available catalyst and not the diffusion of gas so the pellistor response therefore starts to reduce.

Molecule μ	LEL %vol	$-\Delta H_{298}$	$D_{12}@300^\circ\text{C}$	$-\Delta H_{298} D_{12}LEL$	RR vs CH ₄
Methane	4.4	803	0.6851	2421	1.00
Ethane	2.5	1428	0.4613	1647	0.68
Propane	1.7	2044	0.3574	1242	0.51
Butane	1.4	2657	0.3383	1258	0.52
Iso-Butane	1.3	2649	0.3148	1084	0.45
N-Pentane	1.4	3272	0.2717	1245	0.51
Iso-Pentane	1.4	3262	0.2618	1196	0.49
Neo-Pentane	1.4	3250	0.2532	1152	0.48
N-Hexane	1	3887	0.2511	976	0.40
Methylpentane	1	3877	0.2385	925	0.38
Dimethylbutane	1	3865	0.2412	932	0.39
Heptane	1.1	4502	0.2065	1023	0.42
Methylhexane	1.1	4492	0.2147	1061	0.44
Ethylpentane	1.1	4492	0.2168	1071	0.44
Dimethylpentane	1.1	4480	0.2208	1088	0.45
Trimethylbutane	1.1	4471	0.2233	1098	0.45
Octane	0.8	5116	0.1884	771	0.32
Nonane	0.7	5731	0.1713	687	0.28
Decane Mixed Isomers	0.7	6345	0.1588	705	0.29



ClairAir is a member of CoGDEM, the Council of Gas Detection and Environmental Monitoring. CoGDEM is the trade association representing manufacturers of gas detecting apparatus and sensors, as well as service companies such as calibration gas and hazardous area certification providers. www.cogdem.org.uk

AUTHOR DETAILS

Dr Alan Doncaster,
 C.Chem., M.R.S.C.,
 Clairair Ltd,
 Little Braxted Hall,
 Witham Road, Little Braxted,
 Witham, Essex, CM8 3EU
 Tel: +44 (0) 1376 516414
 Fax: +44 (0) 1376 516415
 Email: info@clairair.com

Methane response is normally affected by poisoning before responses to other gases. This is because methane has a higher activation energy for combustion. Therefore a sensor which is being poisoned could show a low methane response but retain a normal response to other gases such as propane. It is therefore normal to calibrate using methane and check for responses to other gases relative to methane rather than calibrate using a different gas and estimate the methane response.

So there are several factors that have an influence on the pellistor response and also on the relative responses. Normally, the larger the molecule the larger the effect and the lower the response. The response of a pellistor to hydrogen is normally affected least and indeed it is extremely difficult to poison a pellistor to hydrogen. Although hydrocarbon infrared sensors are replacing pellistors in many applications, there is still a place for a pellistor as it measures flammability, non-hydrocarbon explosive gases and gases that have very weak infrared signatures.

References:

1. J. G. Firth, Alan Jones and T. A. Jones, *Combustion and Flame*, Volume 20, Iss 3, 303-311, (1973)
2. IEC 61779-1: "Electrical Apparatus for the Detection and Measurement of Flammable Gases – Part 1: General Requirements and Test Methods", International Electrotechnical Commission, 1998
3. Sidney W. Benson and Jerry H. Buss "Additivity Rules for the Estimation of Molecular Thermodynamic Properties" *J. Chem. Phys.* 29: 546. (1958)
4. S.W. Benson, "Thermochemical Kinetics, 2nd Ed.". John Wiley & Sons, New York, 1976.
5. J.O. Hirschfelder, R.B. Bird and E.L. Spatz, *Trans. Am. Soc. Mech. Eng.* 71, 921 (1949).
6. Neufeld et al., *J. Chem.Phys.* 57, 1100 (1972)